



Power, Versatility, Reliability



The QB1 series are portable, robust samplers designed to ensure consistent and precise performance, both in emission measurements and in air quality sampling.

Three configurations for every sampling need

QB1 - Manual

Maximum control and operational simplicity, day after day, even in the most demanding conditions. □ A robust and reliable sampler, designed to last over time.

QB1e - Electronic

The perfect balance between practicality and technology. It retains manual flow rate regulation, but integrates the digital interface that simplifies management and programming. □ Reports, with values already normalized, are generated and displayed directly on board.

Sensor calibration is quick and intuitive: corrections are entered directly into the instrument, ensuring integration into the metrology chain without post-sampling interventions. □ Management is via OLED display and tactile keyboard or via Dadolab Companion APP, which allows quick settings, real-time notifications, download and remote data sending.

QB1z - Digital

Designed to ensure the highest level of automation and connectivity, this configuration ensures fully electronic flow regulation, optimized to minimize consumption. The pump automatically modulates the flow rate according to needs, allowing it to be operated even on battery power. Thanks to wireless integration with the ST2 meter, the constant flow sampler transforms into a fully automatic isokinetic system, offering high performance and maximum efficiency.

QB1: compact, configurable and compliant with international standards, with in-line filter, automatic pressure drop compensation, vacuum gauge and temperature sensor in the DGM for reliable and safe sampling.

QB1: Manual Constant Flow Sampler

The QB1 series represents excellence in portable air sampling, with instruments designed to ensure stability and accuracy even under varying operating conditions.

Thanks to the automatic compensation of in-line pressure drops, each unit ensures reliable operation in both environmental and industrial environments, adapting with versatility to different application needs.

The design has been studied to offer safety and practicality: the surfaces are free of sharp edges and protected by reinforced rubber bumpers, while the technopolymer side handles facilitate transport and allow lifting at height with ropes or hooks.

The structure, solid and resistant, is made of AISI 304 stainless steel, while the secondary components use a Peralluman aluminum alloy, light but robust, finished with high quality surface treatments such as powder coating or anodizing.

Every detail is designed to last: the protection systems against the accidental suction of particulates and liquids preserve the internal integrity of the instrument, while the possibility of stacking the units allows you to optimize space during use, transport and storage.

Thanks to the slots on the side cover, silica gel traps can be securely attached directly to the sampler, preventing them from being placed on the ground where they could get damaged or lose their seal over time, while also encouraging their proper use.

The QB1 models are also equipped with a thermometer for measuring the temperature of the volumetric meter and with a vacuum gauge for monitoring depression along the sampling line, offering complete and precise control at every step of the process.



The evolutions of the QB1 series: enhanced performance



QB1-ADS1: Digital Automatic Sampler: the new frontier of automatic side-line sampling

Dado Lab introduces ADS-1, the first fully automatic sampler for side lines, designed to natively integrate with the ST5 automatic isokinetic sampler.

Unique functions: automatic pressure drop compensation, flow measurement via orifice mass flow meter, volume measurement on DGM, flow control via proportional valve.

Maintaining the flow ratio between main and branch line within $\pm 10\%$ [EN14385, section 5.1.2.6] becomes digital, automatic and continuous.

All side streamline data is captured and stored in the ST5 report, ensuring full traceability and compliant documentation.

Zero manual interventions, maximum precision, total reliability.

When precision is what makes the difference.

QB1-D – Sampler according to the EN 12619 dilution method

Combined with the HP1 heated probe, the QB1-D becomes the ideal instrument for VOC sampling according to the EN 12619 dilution method.

The system is equipped with two independent sampling lines: one takes the sample from the probe, the other provides clean air to ensure a precise and effective dilution process.

The pneumatic circuit is designed to eliminate volume measurement errors due to in-line pressure, ensuring maximum accuracy.

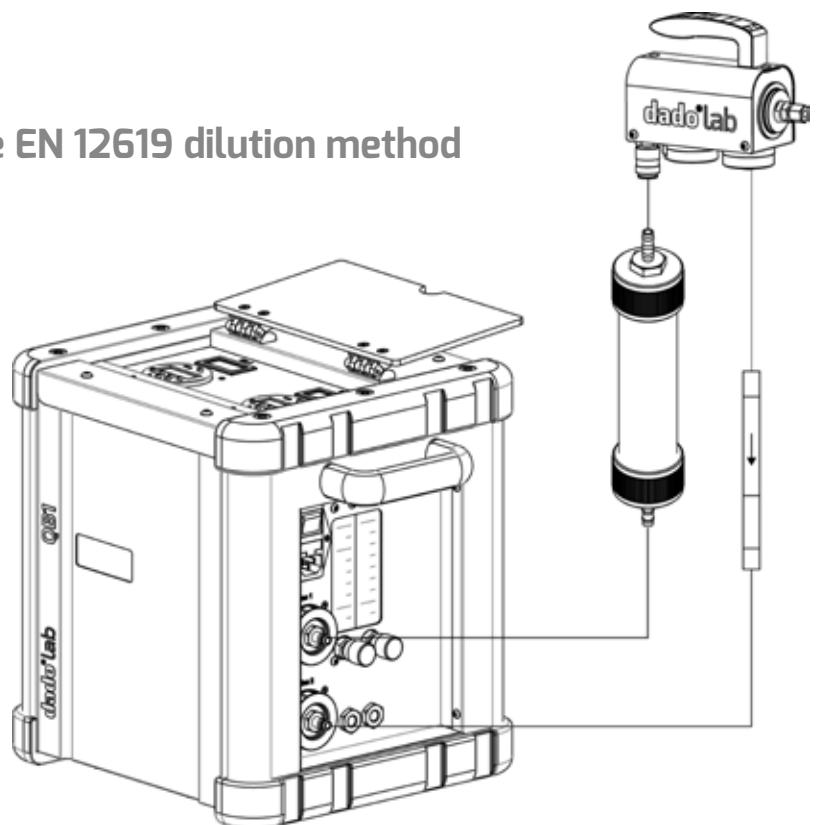

QB1 V2x5 DC: Dual-line battery-powered sampler for simultaneous and independent sampling.



Designed for sampling gaseous compounds in ambient air and emissions, the QB1 V2x5DC excels on branch lines thanks to its automatic pressure drop compensation.

Two independent low-flow lines, complete with filter, flowmeter and volumetric meter, guarantee precision and reliability.

The flow rate can be adjusted from a few cc to 5 l/min and the flow meters can have a specific scale range to adapt to the required need.

The compensation system allows the flow to be interrupted through external valves without shutting down the pump, avoiding suction risks and optimizing the derived sampling.

Two programmable timers manage each line separately, making it ideal for vials and impingers.

Flexible power supply: mains power or built-in lithium or lead-acid batteries for continuous operation anywhere.

QB1e: The intelligent evolution of sampling.

Precise and reliable, the QB1e represents the next generation of the QB1 line: the same robustness, intuitive design and portability, but with advanced digital features.

Flow control remains manual, managed by needle valves with double-scale flowmeters, while the automatic pressure drop compensation system ensures optimal performance even at low flow rates or on side lines.

The real innovation is the digital interface that simplifies programming, data processing and wireless transfer.

The QB1e allows you to set samples by date and time, define the duration based on time or volume, or continue to manual stop.

The modern and intuitive control panel integrates a high-contrast OLED display, a touch polycarbonate keypad and LED indicators for operating status and alarms.

The user can monitor data in real-time, initiate immediate or scheduled sampling, and set end-of-cycle conditions.

The reports, with already normalized values, are automatically saved and accessible directly from the instrument, downloadable via Dado Lab Companion App for quick settings, real-time notifications, download and remote sending, or via dedicated PC software.

Sensor calibration is quick and easy: up to five correction points for volume, DGM temperature and atmospheric pressure, entered directly into the instrument via wireless software, ensuring complete integration into the metrology chain without follow-up interventions.

QB1e: the perfect balance between practicality and technology.



QB1z: The next generation of digital sampling.



The QB1z represents the evolution of the QB1 line: it retains robustness, intuitive design and portability, but introduces two key innovations.

Flow management is fully digital, eliminating regulating needle valves and flow meters. Moreover, thanks to optimized power consumption, continuous operation is supported by high-performance LiFePO₄ batteries, ensuring maximum autonomy and making it natively compatible with multi-voltage power supply from 110 to 230 Vac.

The QB1z samplers are equipped with an ultra-fast automatic flow adjustment system, capable of reaching the set value in less than ten seconds. For low-flow operations, the system provides real-time guidance for bypass valve adjustment, improving flow stability and accuracy.

Thanks to advanced digital management, the QB1z allows you to program samples also based on date and time, define the duration according to the time or volume sampled, or continue until the manual stop.

It can also be equipped with an 8-way multi-ramp valve control module, which allows the sampling of

gaseous compounds through vials or the collection of particulate matter and asbestos with filter holders. Each line can be individually programmed for cycle times and valve configuration.

The modern and intuitive control panel integrates a high-contrast OLED display, a touch polycarbonate keypad and LED indicators for operating status and alarms. The user can monitor data in real-time, initiate immediate or scheduled sampling, and set end-of-cycle conditions.

The reports, with already normalized values, are automatically saved and accessible directly from the instrument, downloadable via Dado Lab Companion App for quick settings, real-time notifications, download and remote sending, or via dedicated PC software.

Sensor calibration is quick and easy: up to five correction points for volume, DGM temperature and atmospheric pressure, entered directly into the instrument via wireless software, ensuring complete integration into the metrology chain without follow-up interventions.

Part Number and accessories

QB1 : delivered with Test reports, quick guide, power cable and quick coupling.

101 110 1101	QB1 V1.5 Constant flow sampler
101 110 1102	QB1 V3.0 Constant flow sampler
101 110 1103	QB1 V5.0 Constant Flow Sampler
101 110 1005	QB1 V2x5DC (220Vac/Pb Batteries) Dual Constant flow sampler
101 110 1005L	QB1 V2x5DC (220Vac/Li Batteries) Dual Constant flow sampler
101 110 1006	QB1-D (220Vac/Batteries) Dilution sampler
101 101 1200	Automatic Derived Sampler ADS-1
101 101 1203	ST5 connection interface for ADS-1

QB1-e : delivered with Test reports, quick guide, power cable and quick coupling.

101 110 1201	QB1e V1.5 Electronic constant flow sampler
101 110 1202	QB1e V3.0 Electronic constant flow sampler
101 110 1203	QB1e V5.0 Electronic constant flow sampler

QB1-z : delivered with Test reports, quick guide, power cable and quick coupling.

101 110 1300	QB1z V1.0 Digital constant flow sampler
101 110 1301	QB1z V1.5 Digital constant flow sampler
101 110 1302	QB1z V3.0 Digital constant flow sampler

Accessories QB1z

102 103 4030	Manifold interface for QB1z
102 103 4031	8-ways manifold for QB1z
102 105 2047	LiFePO4 15Ah 24V battery for QB1z
102 105 2048	LiFePO4 30Ah 24V battery for QB1z

Common spares

101 110 4001	QB1 G2.5 Spare DGM
101 110 4001A.....	QB1 G1.6 Spare DGM

Common accessories

101 110 4002	Silica gel/Charcoal trap 100cc
101 110 4003	Silica gel/Charcoal trap 1 lt
300 104 1001	QB1 Leak test flowmeter kit 20-100 Ncc/min
300 104 1002	QB1 Leak test flowmeter kit 200-1500 Ncc/min
101 110 4004	Sampling media support stand
101 110 4005	47mm open filterholder HB
101 110 4006	Pack of 5 47mm open filterholder cassettes
101 110 4014	Telescopic tripod with clamp
101 110 4015	47mm open filterholder QC
101 101 3010	Inlet gas protection filter, box of 10 pcs

Technical Characteristics

Common Technical Characteristics	
Sampled Gas Condition	Dehumidified, max temperature 45°C
Gas inlet	With liquid and particulate protection filter
Connection with quick couplings	
Operating Conditions	-10 ÷ 40°C, 95% UR
Storage Conditions	-10 ÷ 50°C, 95% UR
Power supply	230 Vac ±10% 50/60Hz
Materials	Stainless steel and aluminium composite
Dimensions (LxWxH)	330 x 310 x 360 mm
Suction pressure drop	
Vacuum gauge	Range 0 ÷ -1 Bar
Accuracy	±5%

	QB1 V1.5 / QB1e V1.5	QB1 V3.0 / QB1e V3.0	QB1 V5.0 / QB1e V5.0
Pump	Single Head diaphragm	Double head diaphragm	Rotary vane
Nominal flowrate pump	32 l/min	55 l/min	5 m3/h
Weight	9 Kg	11Kg	13 Kg
Power supply	230Vac ± 10% 50/60Hz	230Vac ± 10% 50/60Hz	230Vac ± 10% 50/60Hz
Consumption	50W	100W	150W
Sensor features			
Volume			
DGM	G1.6	G2.5	G2.5
Range	0.016 m³/h ÷ 2.5 m³/h	0.025 m³/h ÷ 4.0 m³/h	0.025 m³/h ÷ 4.0 m³/h
Accuracy	2% reading	2% reading	2% reading
Resolution	0.1 liters	0.1 liters	0.1 liters
DGM Temperature			
Range	-50 ÷ +100°C	-50 ÷ +100°C	-50 ÷ +100°C
Accuracy	±1°C	±1°C	±1°C
Resolution	0.1°C	0.1°C	0.1°C
Flow meter	Rotameter	Rotameter	Rotameter
Flow meter scale indication	0.2 ÷ 3.0 / 2 ÷ 30 nl/min	0.2 ÷ 3.0 / 2 ÷ 30 nl/min	2 ÷ 30 / 2 ÷ 30 nl/min
Accuracy	±5% F.S.	±5% F.S.	±5% F.S.
Unique Features QB1e Series			
Display	2.5-inch high-brightness OLED display	2.5-inch high-brightness OLED display	2.5-inch high-brightness OLED display
Keyboard	Polycarbonate with tactile effect keys	Polycarbonate with tactile effect keys	Polycarbonate with tactile effect keys
Data management	Via Dadolab Companion APP Calibration and data download via Windows PC	Via Dadolab Companion APP Calibration and data download via Windows PC	Via Dadolab Companion APP Calibration and data download via Windows PC
Barometric pressure			
Range	50 ÷ 115 Kpa (1150 mBar)	50 ÷ 115 Kpa (1150 mBar)	50 ÷ 115 Kpa (1150 mBar)
Hysteresis and linearity	0.25%	0.25%	0.25%
Resolution	0.01 KPa (0.1 mBar)	0.01 KPa (0.1 mBar)	0.01 KPa (0.1 mBar)
Accuracy	Better than di 1% (±0.25KPa)	Better than di 1% (±0.25KPa)	Better than di 1% (±0.25KPa)

Technical Characteristics

	QB1z V1.0	QB1z V1.5	QB1z V3.0
Power supply	Multi-voltage: 110 Vac ÷ 230 Vac ±10% 50/60Hz Optional battery operation available	Multi-voltage: 110 Vac ÷ 230 Vac ±10% 50/60Hz Optional battery operation available	Multi-voltage: 110 Vac ÷ 230 Vac ±10% 50/60Hz Optional battery operation available
Consumption	50W	50W	100W
External battery option	15Ah - 24Vdc, Weight 1.9Kg 30Ah - 24Vdc, Weight 2.5Kg	15Ah - 24Vdc, Weight 1.9Kg 30Ah - 24Vdc, Weight 2.5Kg	15Ah - 24Vdc, Weight 1.9Kg 30Ah - 24Vdc, Weight 2.5Kg
Durata minima			9 hours with 15Ah at 25 l/min and 10Kpa Pdrop 14 hours with 30Ah at 25l/min and 10Kpa Pdrop
Display	2.5-inch high-brightness OLED display	2.5-inch high-brightness OLED display	2.5-inch high-brightness OLED display
Keyboard	Polycarbonate with tactile effect keys	Polycarbonate with tactile effect keys	Polycarbonate with tactile effect keys
Pump	Single Head diaphragm	Single Head diaphragm	Double head diaphragm
Nominal flowrate pump	14 l/min	32 l/min	55 l/min
Minimum settable flow rate	0,3 l/min	0,3 l/min	0,5 l/min
Weight	9 Kg	9 Kg	11Kg
Sensor features			
Volume			
DGM	G1.6	G1.6	G2.5
Range	0.016 m³/h ÷ 2.5 m³/h	0.016 m³/h ÷ 2.5 m³/h	0.025 m³/h ÷ 4.0 m³/h
Accuracy	2% reading	2% reading	2% reading
Resolution	0.1 liters	0.1 liters	0.1 liters
DGM Temperature			
Range	-20 ÷ +70°C	-20 ÷ +70°C	-20 ÷ +70°C
Accuracy	±1°C	±1°C	±1°C
Resolution	0.1°C	0.1°C	0.1°C
Flow meter	Electronic	Electronic	Electronic
Accuracy	2% reading	2% reading	2% reading
Resolution	0.1 liters	0.1 liters	0.1 liters
Barometric pressure			
Range	50 ÷ 115 Kpa (1150 mBar)	50 ÷ 115 Kpa (1150 mBar)	50 ÷ 115 Kpa (1150 mBar)
Hysteresis and linearity	0.25%	0.25%	0.25%
Resolution	0.01 Kpa (0.1 mBar)	0.01 Kpa (0.1 mBar)	0.01 Kpa (0.1 mBar)
Accuracy	Better than di 1% (±0.25KPa)	Better than di 1% (±0.25KPa)	Better than di 1% (±0.25KPa)

QB1 2x5 DC e QB1-D	
Gas inlet	With particulate protection filter
Pump	N°2 single head diaphragm
Nominal flowrate pump	11 l/min
Flow meter	Rotameter
Flow meter scale indication	0.2 ÷ 5.0 / 0.2 ÷ 5.0 nl/min
Other ranges on request	
Accuracy	±5% F.S.
Weight	13 Kg including batteries
Power and consumption	230Vac ± 10% 50/60Hz - 50W
Built-in battery OPT1	Lead Acid Pb 24 Vdc 2.3Ah
Minimu duration	4h 1 line, 2h 2 lines
Built-in battery OPT2	Lithium 24 Vdc 15Ah
Minimum duration	30 hours 1 line, 15 hours 2 lines
Digital timer	ON/OFF Programming, Date & Time, Lithium Backup Battery, Automatic restart in case of mains failure, Automatic/Manual function
Volume	
DGM	G1.6
Range	0.016 m³/h ÷ 2.5 m³/h
Accuracy	2% della misura
Resolution	0.1 litri
DGM Temperature	
Range	-50 ÷ +100°C
Accuracy	±1°C
Resolution	0.1°C

Technical Characteristics

QB1 ADS-1	
Gas inlet	With liquid and particulate protection filter
Pump	Single Head diaphragm
Flowrate	0.250 ÷ 5.000 NI/min
Flow meter	Electronics via orifice mass flow meter
Regulation	Proportional valve
Weight	9 Kg
Power and consumption	230Vac ± 10% 50/60Hz - 50W
Volume	
DGM	G1.6
Range	0.016 m³/h ÷ 2.5 m³/h
Accuracy	2% reading
Resolution	0.1 liters
DGM Temperature	
Range	-50 ÷ +100°C
Accuracy	±1°C
Resolution	0.1°C

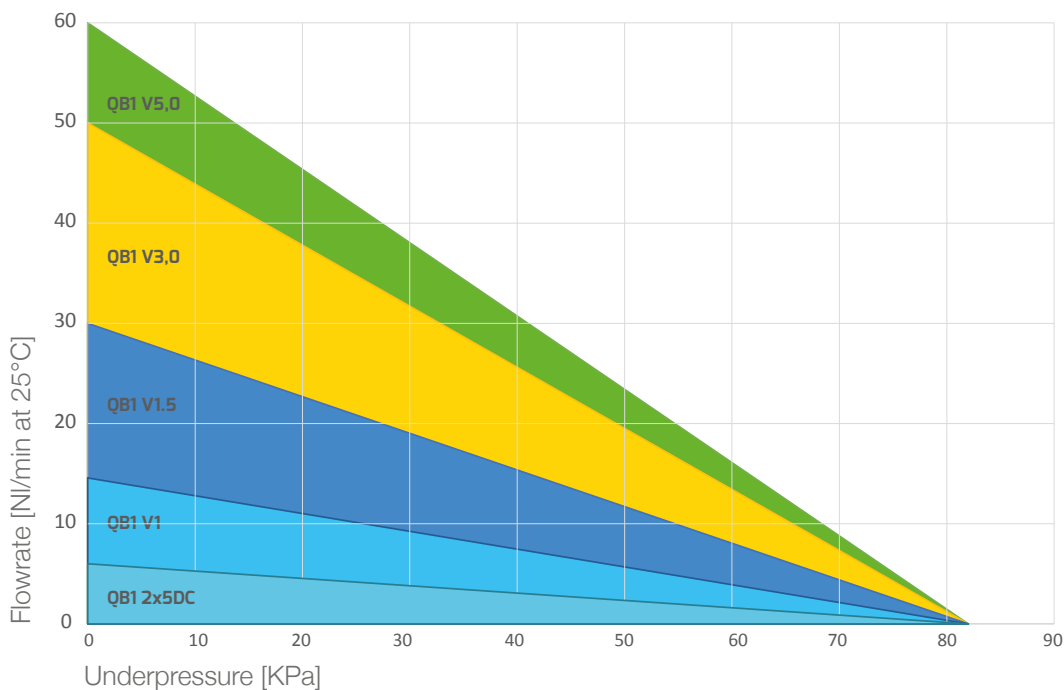

Performance Curve
QB1 Pumps

Dimensions (mm)

